

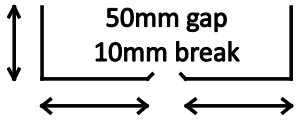



BGJ Box Gutter Joiner

BGJ Installation Instructions

1. Take measurements of existing box gutter.	
2. Fabricate the two 'L' shaped box gutter halves. Leave 50mm gap in the centre and fold 10mm breaks.	 <p>The diagram shows an L-shaped profile. A vertical double-headed arrow on the left indicates the height. A horizontal double-headed arrow below the profile indicates the width. In the center of the horizontal flange, there is a gap labeled '50mm gap' and a small notch labeled '10mm break'.</p>
3. Cut old gutter in the centre and remove.	
4. Place one 'L' shaped half.	 <p>The diagram shows a single L-shaped gutter half resting on a flat surface.</p>
5. Place bottom plate of joiner and secure to gutter with rivets	 <p>The diagram shows the L-shaped gutter half with a small rectangular plate (the bottom plate of the joiner) being attached to its horizontal flange. A small rivet is shown securing the plate.</p>
6. Place other 'L' shaped half and again rivet.	 <p>The diagram shows the second L-shaped gutter half being placed on top of the first half, with a rivet shown at the center of the joint.</p>
7. Place next bottom plate with 20mm overlap and hold with rivet.	 <p>A 3D perspective diagram showing a rivet being driven through the bottom plate of the joiner into the gutter half. An arrow points to the rivet with the label 'Rivet'.</p>
8. Place next 'L' shaped halves.	 <p>A 3D perspective diagram showing the completed gutter assembly, consisting of multiple L-shaped gutter halves joined together with rivets.</p>

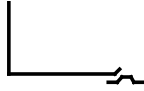
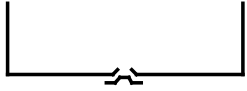
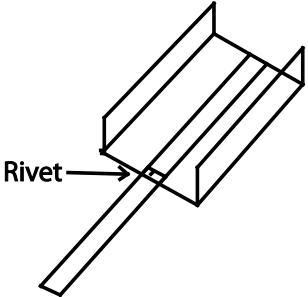
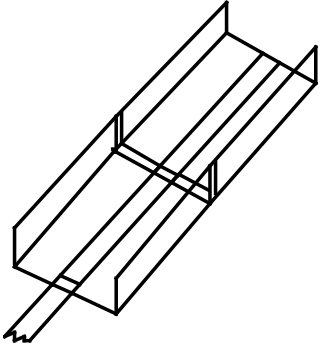
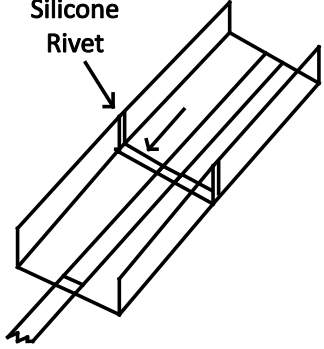
<p>9. Seal and rivet laps.</p>	
<p>10. Place top plate of joiner on first section, make sure rubber seals are seated correctly, cut joiner wings at end for neat overlap.</p>	
<p>11. Use washers and bolts to secure top plate securely.</p>	
<p>12. Fix with rivets and silicone seal along joiner edge.</p>	
<p>13. Place next bottom plate and continue procedure.</p>	
<p>14. Box Gutter Ends: Cut and fold sides in, silicone and join with rivets.</p>	
<p>15. Sump: Same as with conventional box gutter.</p>	

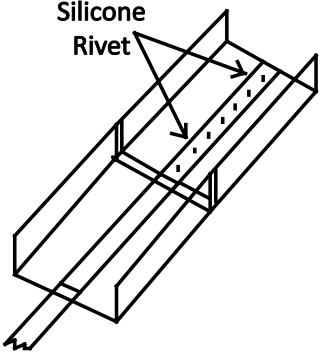
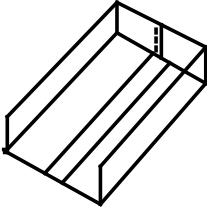
Technical Support:

Andrew Boyadjian

Ph: 0403089098

info@box-gutter-joiner.com.au

www.box-gutter-joiner.com.au